



+91 9012112527

indiamahadeventerprises@gmail.com



COMPANY PROFILE

Mahadev Enterprises is a trusted name dedicated to promoting fitness, wellness, rehabilitation, and healthy living through innovation, quality, and commitment. Our vision is to contribute to the growth of the wellness and fitness industry by providing premium-quality Pilates equipment, rehabilitation solutions, physiotherapy equipment, and modern fitness infrastructure designed to meet evolving industry standards.

With a vision to make wellness and movement-based fitness more accessible and effective, Mahadev Enterprises continuously works towards supporting Pilates studios, physiotherapy centers, rehabilitation clinics, wellness institutes, fitness professionals, and healthcare organizations with reliable, innovative, and performance M-driven solutions.

Our Commitment

Our commitment extends beyond manufacturing and supplying equipment—we strive to create opportunities for healthier lifestyles, improved physical well-being, and professional growth within the wellness industry. Through superior craftsmanship, ergonomic designs, and customer-focused service, we deliver products that combine durability, functionality, safety, and excellence.

Specializing in Pilates and rehabilitation equipment, we understand the importance of precision, comfort, and performance in every product we offer. Our solutions are designed to help professionals deliver effective training, recovery, and wellness experiences while meeting the highest standards of quality and reliability.

Driven by passion and guided by professionalism, Mahadev Enterprises continues to move forward with the mission of empowering individuals and organizations through wellness, rehabilitation, Pilates, and innovation.



		Model no
Maple Pilates Reformer		M-01
Maple Reformer With Tower		M-02
Alluminium Reformer with Tower		M-03
Maple Foldable Reformer		M-04
Maple The Cadillac		M-05
Maple 3-in-1 Caformer		M-06
Maple Ladder Barrel		M-07
Maple Wunda Chair		M-08
Aluminium Wunda Chair		M-09
Alluminium ladder Barrel		M-10
Maple Spine Corrector		M-11
Accessories		--

PILATES REFORMER (M-01)

The Professional Studio Foundation

A premium, studio-grade reformer built for full-body conditioning and core stability, offering a smooth and silent workout experience.



Key Features & Value

- Crafted from high-quality Maple or Rubber wood for maximum durability.
- High-density foam padding with customizable black leather upholstery.
- Six-spring resistance system for precision tension control.

SPECIFICATIONS

- Product Dimensions
228 X 73 X 34.7 cm
- Net Weight
92 kg

DIMENSIONS



MATERIAL



MAPLE WOOD

High-quality maple wood frame ensures strength, stability, and a natural aesthetic.

REFORMER WITH TOWER (M-02)

Advanced Vertical Training System

Combines standard reformer exercises with tower-based resistance for a comprehensive 3D workout experience.



Key Features & Value

- Full stainless steel tower frame for multi-angle resistance.
- Precision-balanced pulley system for fluid movement.
- Includes maple roll-up pole, shoulder rests, and foot straps.

SPECIFICATIONS

- **Product Dimensions**
230 x 75 x 34.5 cm
(approx.)
- **Net Weight**
119 kg
(varies by model)

DIMENSIONS



MATERIAL



MAPLE WOOD

High-quality maple wood frame ensures strength, stability, and a natural aesthetic.

ALLUMINIUM REFORMER WITH TOWER (M-03)

Ergonomic Postural Alignment



Key Features & Value

- **Posture Improvement:** Supports spinal alignment and corrects imbalances through controlled movements.
- **Full-Body Training:** Engages core, arms, legs, and back using adjustable resistance springs.
- **Tower Integration:** Adds vertical workout options like push-through bar and arm springs for advanced routines.
- **Rehabilitation Support:** Suitable for injury recovery and low-impact strengthening exercises.

SPECIFICATIONS

- **Product Dimensions**
240 x 70 x 200 cm
(approx.)
- **Net Weight**
65–85 kg
(varies by model)

DIMENSIONS

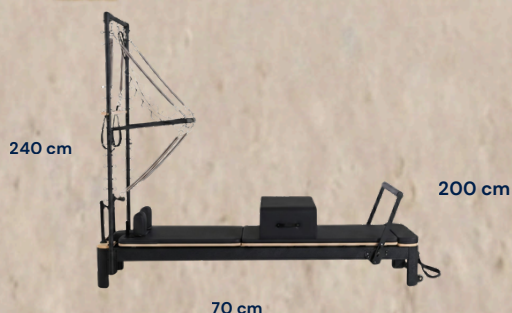

MATERIAL



ALUMINIUM FRAME

Corrosion-resistant stainless steel tower frame for enhanced durability and safety.

FOLDABLE REFORMER (M-04)

Professional Grade, SpacM-Saving Design

A versatile, spacM-saving reformer ideal for home studios or compact training areas without compromising on performance.

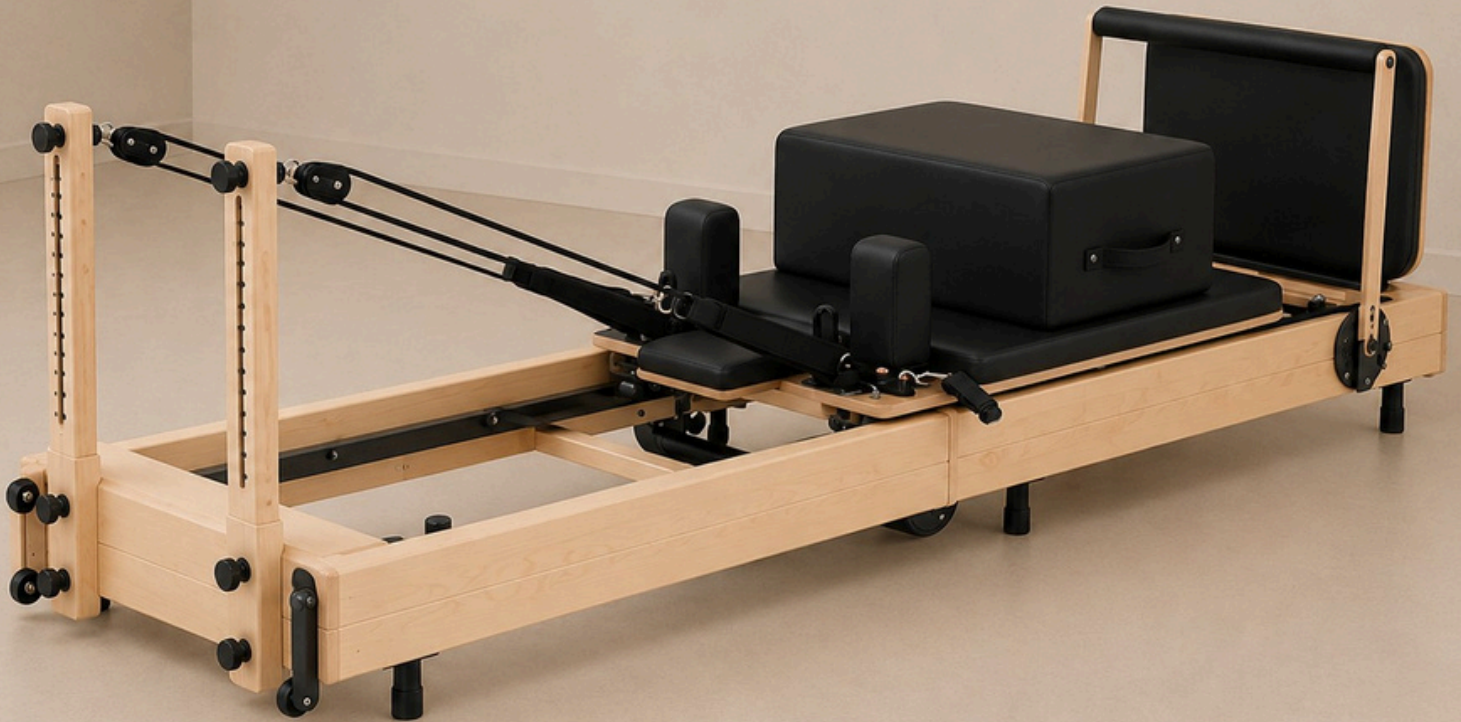

Key Features & Value

- Easy-fold mechanism for convenient storage and portability.
- Equipped with a mobile cushion and adjustable column.
- Includes jumping board and reformer box for varied exercise routines.

SPECIFICATIONS

- **Product Dimensions**
230 x 69 x 58 cm
(approx.)
- **Net Weight**
65–85 kg
(varies by model)

DIMENSIONS

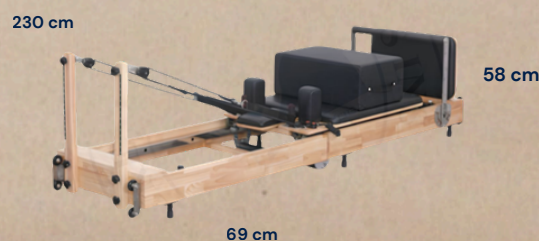

MATERIAL



MAPLE WOOD

High-quality maple wood frame ensures strength, stability, and a natural aesthetic.

THE CADILLAC (M-05)

The Ultimate Rehabilitation Powerhouse

A complete trapeze table designed for the most comprehensive Pilates training, ideal for rehabilitation and advanced flexibility.



Key Features & Value

- Solid wooden base with a full overhead trapeze frame.
- Extensive spring kit for targeted limb and core rehabilitation.
- Wide, stable platform with antibacterial leather cover.

SPECIFICATIONS

- **Product Dimensions**
217 x 69 x 57 cm
(approx.)
- **Net Weight**
65–85 kg
(varies by model)

DIMENSIONS



MATERIAL

MAPLE WOOD

High-quality maple wood frame ensures strength, stability, and a natural aesthetic.

Corrosion-resistant stainless steel tower frame for enhanced durability and safety.

3-IN-1 CAFORMER (M-06)

Reformer, Cadillac & Mat Hybrid



A professional hybrid offering the widest range of exercises in a single footprint, allowing seamless transitions between modes.



Key Features & Value

- Heavy-duty build to support intense studio usage.
- Seamless transition between reformer and trapeze table modes.
- Includes all essential accessories: box, handles, and spring sets.

SPECIFICATIONS

- **Product Dimensions**
228 x 85x 57cm
(approx.)
- **Net Weight**
165–169 kg
(varies by model)

DIMENSIONS

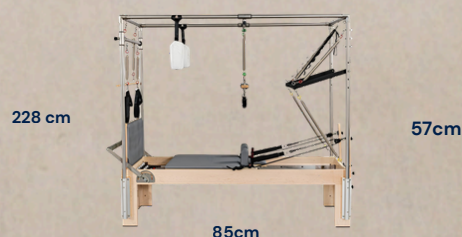

MATERIAL



MAPLE WOOD

High-quality maple wood frame ensures strength, stability, and a natural aesthetic.



STAINLESS STEEL

Corrosion-resistant stainless steel tower frame for enhanced durability and safety.

LADDER BARREL (M-07)

*Spinal Alignment &
Flexibility Specialist*

Specifically designed for deep stretching, spinal decompression, and core strength with adjustable settings for all body types.



Key Features & Value

- Adjustable sliding base to customize distance between ladder and barrel.
- Reinforced wooden ladder rungs for secure grip and stability.
- High-density foam barrel for maximum comfort during inversions.

SPECIFICATIONS

- Product Dimensions
112 x 63 x 89 cm
(approx.)
- Net Weight
30-40 kg
(varies by model)

DIMENSIONS



MATERIAL



MAPLE WOOD

High-quality maple wood frame ensures strength, stability, and a natural aesthetic.

WUNDA CHAIR (M-08)

Compact Balance & Coordination Tool
A versatile pedal-based system that targets the core and lower body with a minimal footprint, perfect for balance work.



Key Features & Value

- Adjustable spring tension for varying difficulty levels.
- Includes removable stability handles with adjustable height.
- Compact and mobile for easy relocation within the studio.

SPECIFICATIONS

- Product Dimensions
79 x 65 x 60 cm
(approx.)
- Net Weight
25–30 kg
(varies by model)

DIMENSIONS



MATERIAL



MAPLE WOOD

High-quality maple wood frame ensures strength, stability, and a natural aesthetic.

ALUMINIUM WUNDA CHAIR (M-09)

Compact Strength & Postural Control

The Aluminium Wunda Chair is a compact and versatile Pilates equipment designed to improve strength, balance, and body control.



Key Features & Value

- **Strength Building:** Targets core, arms, legs, and back with resistance-based movements.
- **Balance & Stability:** Enhances coordination and posture through controlled exercises.
- **Adjustable Resistance:** Spring system allows customized intensity for all fitness levels.
- **Compact Design:** Space-saving structure suitable for home and studio use.

SPECIFICATIONS

- **Product Dimensions**
80 x 70 x 130 cm
(approx.)
- **Net Weight**
40–50 kg
(varies by model)

DIMENSIONS



MATERIAL



STAINLESS STEEL

Corrosion-resistant stainless steel tower frame for enhanced durability and safety.

ALLUMINIUM LADDER BARREL (M-10)

Spinal Flexibility & Core Extension

The Aluminium Ladder Barrel is a premium Pilates apparatus designed to improve spinal flexibility, core strength, and posture. It features a curved padded barrel and a ladder with multiple rungs, allowing users to perform both stretching and strengthening exercises.



Key Features & Value

- **Spine Stretching:** Supports deep back extension and spinal alignment through natural curve design.
- **Core Strengthening:** Enhances abdominal and back muscles using gravity-based resistance.
- **Adjustable Structure:** Sliding base allows customization for different body sizes and flexibility levels.
- **Multi-Exercise Use:** Suitable for stretching, strengthening, and advanced Pilates movements.

SPECIFICATIONS

- **Product Dimensions**
120 x 90x 100 cm
(approx.)
- **Net Weight**
35–50 kg
(varies by model)

DIMENSIONS



MATERIAL



STAINLESS STEEL

Corrosion-resistant stainless steel tower frame for enhanced durability and safety.

SPINE CORRECTOR (M-11)

Ergonomic Postural Alignment

The Spine Corrector (M-06) is a specialized piece of Pilates equipment designed to improve posture, increase spinal flexibility, and support ergonomic alignment. Unlike the rolling creeper seat you previously asked about, this is a fitness and rehabilitation tool.



Key Features & Value

- **Improves Posture:** Corrects slouching and rounded shoulders by aligning the spine.
- **Spinal Relief:** Relieves back tension and increases flexibility through gentle extension.
- **Chest Opening:** Expands the chest area to improve breathing and mobility.
- **Portable & Compact:** Lightweight design makes it easy to store or carry between home and the studio.

SPECIFICATIONS

- **Product Dimensions**
95 x 45 x 34 cm
(approx.)
- **Net Weight**
10–12kg
(varies by model)

DIMENSIONS



MATERIAL



MAPLE WOOD

High-quality maple wood frame ensures strength, stability, and a natural aesthetic.

Accessories



Ladder
(Aluminium)



Ladder
(Maple wood)



Barrel



Standing Plate

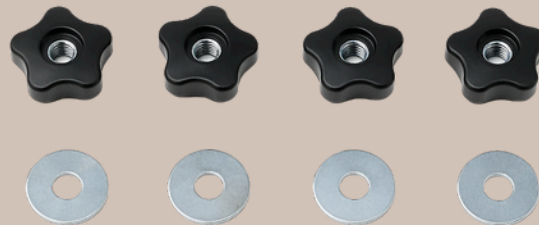

Screw kit



Wooden pole

Accessories

Frame (Aluminium)

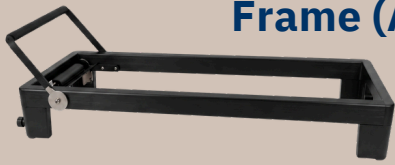

Frame (maple wood)



Carriage

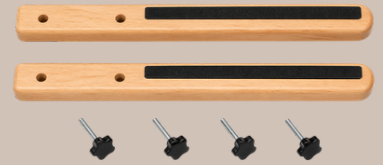

Riser



Jumping Board



Extension

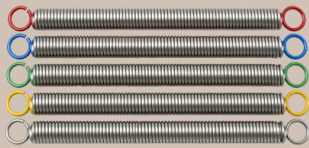

Carriage Spring



Reformer Box



Shoulder Handle

Pulley

Shoulder Rest

Rope

Strap

Headrest